Integrated urban development concept of Jugla

Compilation of conclusions made in the frame of *Urb. Energy* project

2011, Riga City Council



Part-financed by the European Union
(European Regional Development
Fund and European Neighbourhood
and Partnership Instrument).



AUTHORS

Compilation, structure and layout:

Benita FRĒLIHA (Energy efficiency expert of *Urb.Energy* project, Riga City Council).

Urban development:

Normunds STRAUTMANIS (Spatial development expert of *Urb.Energy* project, Riga City Council).

Multi-apartment building renovation:

Laimdota ŠNĪDERE (building manager, *Urb.Energy* project external expert),

Vilis KRUMINS (energy auditor, *Urb.Energy* project external expert).

Energy supply:

Juris GOLUNOVŠ (Energetics expert, Riga City Council).

Financial strategies:

Maija RUBĪNA (Financial analyst, Riga City Council),

Zigo RUTKOVSKIS (Financial analyst, *Urb.Energy* external expert).

Management of *Urb.Energy* project:

V.Hofmarks, B.Freliha (SIA „Pilsetbuvnieks“, www.rigaspilsetbuvnieks.lv), +371-67105122,

Valdis.Hofmarks@riga.lv, bfreliha@latnet.lv

TABLE OF CONTENTS

Introduction	4
Planning principles	5
General information	7
1. Urban areas (<i>general information</i>)	7
2. Multi-apartment buildings (<i>general information</i>)	8
3. Energy supply (<i>general information</i>)	8
Conclusions of SWOT analyses	9
1. Urban areas (<i>conclusions of SWOT analyses</i>)	9
2. Multi-apartment buildings (<i>conclusions of SWOT analyses</i>)	13
3. Energy supply (<i>conclusions of SWOT analyses</i>)	17
Development actions	20
1. Urban areas (<i>development actions</i>)	20
2. Multi-apartment buildings (<i>development actions</i>)	23
3. Energy supply (<i>development actions</i>)	26
Financing and organization	28
1. Urban areas (<i>financing and organization</i>)	28
2. Multi-apartment buildings (<i>financing and organization</i>)	29
3. Energy supply (<i>financing and organization</i>)	31
Summary	32
1. Urban areas (<i>summary</i>)	32
2. Multi-apartment buildings (<i>summary</i>)	34
3. Energy supply (<i>summary</i>)	37

Introduction

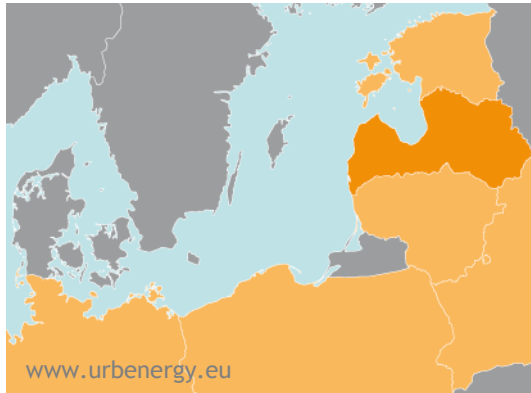

Pic.1 Partner countries of *Urb.Energy* project: DE, PL, BY, LT, LV, EE

The integrated urban development concept of Jugla (IUDC of Jugla) was elaborated in the frame of an international project “Energy Efficient and Integrated Urban Development Action” (Baltic Sea Region Program 2007-2013, abbreviation *Urb.Energy*) by Riga City Council.

The aim of the integrated concept is to reach a high

and long lasting residential and economical quality of the particular neighborhood of Riga - Jugla, while paying a lot of attention to energy efficient solutions thus ensuring sustainability of the planned development. The four fields: urban development, energy efficient renovation of multi-apartment buildings, energy supply and optimal financial and organizational approaches are covered.

The IUDC of Jugla is a document prepared in accordance with “Riga long-term development strategy till the year 2025” and “Riga development program 2006-2012” and is a structured compilation of main conclusions of the following concepts and researches elaborated within the *Urb.Energy* project:

- [1] Sustainable development concept for Jugla (SIA “Grupa93”, contract No. 5-5.3/2010-14);
- [2] Concept for energy efficient renovation of the building stock of Jugla (SIA “Pilsetmaju parvaldnieks”, contract No.5-5.3/2010-1),

- [3] Financial concept for urban improvements in Jugla (N.Strautmanis, Riga City Council),
- [4] Financial concept for energy efficient renovation of the building stock of Jugla (Z.Rutkovskis, contract No. 5-5.3/2010-3).

The IUDC of Jugla additionally includes results of the following surveys and analyses, all elaborated within the *Urb.Energy* project:

- [5] Sample documentation, including renovation design of a multi-apartment building of series No.464 (SIA “Eko Energija”, contract No. 5-5.3/2010-21),
- [6] Visual identity for the multi-storey building blocks in Jugla neighbourhood (SIA “Sestais stils”, contract No. 5-5.3/2010-22),
- [7] Monitoring of indoor climate and consumption parameters of apartments in renovated and not renovated buildings (SIA „Kaiminiem.lv“, contract No. 5-5.3/2010-13),
- [8] Opinion survey of the multi-apartment building inhabitants of Jugla (SIA „Baltkonsults“, contract No. 5-5.3/2010-12),
- [9] Seminars for the multi-apartment building inhabitants of Jugla (SIA „COWI Latvia“, contract No. 5-5.3/2010-2).

“Riga long-term development strategy till the year 2025” defines 13 aims for city’s development, four of which are the priority aims (PA) and nine are the strategical aims (SA) for attaining social, economical and urban quality in Riga.

Development of Jugla would contribute in reaching the priority aim PA4 “Life in a city with qualitative neighborhoods” and the strategical aims SA10 “Green city with good environmental quality” and SA12 “A city with qualitative dwellings”.

Improvement of energy efficiency of multi-apartment buildings and energy supply system would also contribute in reaching the aims of EU Recast Directive on Energy performance of buildings.

Planning principles

The aim of Jugla as a residential neighborhood of high quality was set for the IUDC of Jugla. In preparation of the concept both methods top-down and bottom-up were used. For the urban areas part the particular problems and their solutions were detected by the bottom-up method, also a general principle of energy efficiency was applied. In planning of the development of multi-apartment buildings and energy supply system top-down approach had to be used. Requirements of “Riga long-term development strategy till the year 2025” and EU Recast Directive on Energy performance of buildings were taken as binding.

The planning process of Jugla neighborhood consisted of three stages.

During the first planning stage the particular aims and tasks of “Riga long-term development strategy till the year 2025” in achievement of which development of Jugla neighborhood would contribute were recognized:

Priority Aim PA4 “Life in a city with qualitative neighborhoods” and its Tasks:

- T4.1 Development of local centers of neighborhoods as sub-centers of the city;
- T4.2 Ensure easy reach from the city center by development of qualitative and sufficient street network;
- T4.3 Distribution of municipal services closer to neighborhoods;
- T4.4 Revitalization and development of the degraded territories of the city;
- T4.5 Improvement of the visual and aesthetic quality of the neighborhoods of the city;
- T4.6 Provision of city territories with the necessary engineering networks;
- T4.7 Ensure rational and sustainable usage of city territories;

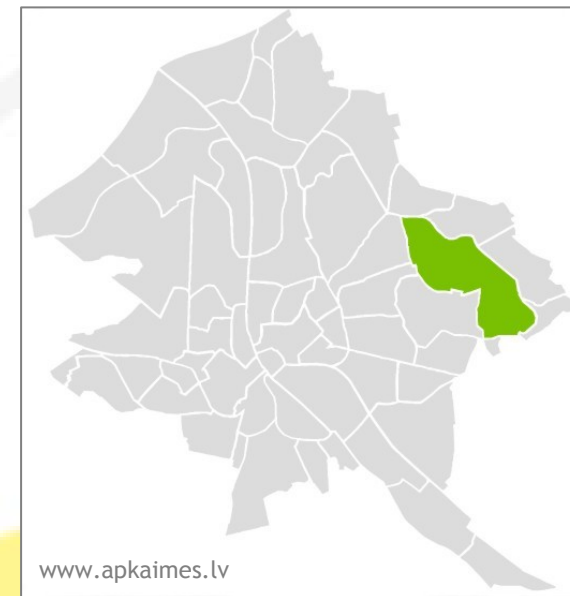

Pic.2, Jugla (green colour) and other neighbourhoods of Riga

- T4.8 Development of qualitative recreational places for city inhabitants.

Strategical aim SA10 „Green city with good environmental quality” and its Tasks:

- T10.1 Effective management and facilitation of city’s greeneries and recreational areas;
- T10.2 Promotion of waste management system development;
- T10.3 Reorganization and recovery of the closed dumpsites;
- T10.4 Ensure protection of water resources;
- T10.5 Improvement of air quality;
- T10.6 Improvement and maintenance of the environment monitoring and information systems;
- T10.7 Reduction of noise pollution in the city;
- T10.8 Provision of drinking water quality complying with EU standards.

Strategical aim SA12 "A city with qualitative dwellings" and its Tasks:

- T12.1 Promotion of availability of financially affordable dwellings in the city;
- T12.2 Promotion of the social building construction programs;
- T12.3 Promotion of renovation and facilitation of privately owned buildings;
- T12.4 Ensure renovation of buildings owned by municipality and maintenance and improvement of the infrastructure;
- T12.5 Promotion of improvements of buildings ensuring availability for disabled persons;
- T12.6 Development of monitoring system of building stock;
- T12.7 Promotion of rational use of heat and electricity in dwellings.

During the second planning stage detailed SWOT analyses were carried out finding strengths, weaknesses, opportunities and threats for development of Jugla neighborhood while paying special attention to urban environment, multi-apartment buildings and energy supply. The findings and the problems are shown in the chapter *Conclusions of SWOT analyses*.

During the third planning stage the necessary activities to solve the problems were found. The activities are listed in the chapter *Development actions* together with the information to which aims and tasks of the "Riga long-term development strategy till the year 2025" they correspond, which problems they help to solve and which institutions are responsible for their implementation.

During the fourth planning stage the financial and organizational approaches for implementation of activities were developed and described (chapter *Financing and organization*).

All SWOT, development and financial details in chapters of "Integrated urban development concept of Jugla" are organized respecting to the three fields: urban environment, multi-apartment buildings and energy supply, which are the main basis for a residential neighborhood (Pic.2).



Pic.3, Scheme of the integrated urban planning principles of *Urb.Energy* project: urban development, energy supply, financing (above); and the project partner cities (below).

General information

The characteristics of neighborhood Jugla:

Area - 1409.9 ha (14km²);

Location - on the Eastern side of Riga, 8km away from the city centre, almost on the outer border of Riga;

Inhabitants - 26 thousand in total (Riga City Council data of November 2011) (2008), density of inhabitants 18 per ha, 95% of residents live in multi-apartment buildings, 5% of residents live in detached houses;

Employment - 500 enterprises employ 6300 people;

Social infrastructure - 8 schools, 9 preschool facilities, Academy of Sports;

Territory - Jugla lays besides two lakes (Kisezers lake and Jugla lake) and has three smaller lakes, some flooded territories; large territories (41%) are covered by woods, 23% of Jugla territory are covered by water, 9% are covered by residential buildings; 2% are covered by technical buildings and 7% by streets and roads;

Transportation - public transport system that connects Jugla to city center has 3 tramlines, 9 bus and 9 minibus lines and 1 train line; railway and the main road of Riga (Brivibas str.) cross Jugla;

Special features - a small district for blind people located in Jugla.



Pic.4, Border of neighborhood Jugla

1. Urban areas (general information)

Jugla is the second largest neighborhood of Riga, approximately three times larger than the average neighborhood, and has a complex spatial structure. Due to the location near the city border Jugla serves as a city gate.

Jugla is spatially fragmented and several regions can be distinguished:

Residential Jugla (dwelling quarters on both sides of Brivibas gatve and along the Malienas st. and Murjanu st.);

Maskernieku village (the part of Jugla to the North of the railway); Strazdumuiza (the quarter between Brivibas gatve, Juglas st. and Pales st., placed besides Jugla lake);

Blind people village (the quarter placed besides Jugla lake and Pales st.);

Fur-farm village (the quarters placed between Maza Jugla st. and the Jugla lake).

As a center of Jugla the district around the Brivibas gatve and Juglas st. junction can be identified where Jugla market, public transport hub, terminal of tramline No.6 and a petrol station are placed.

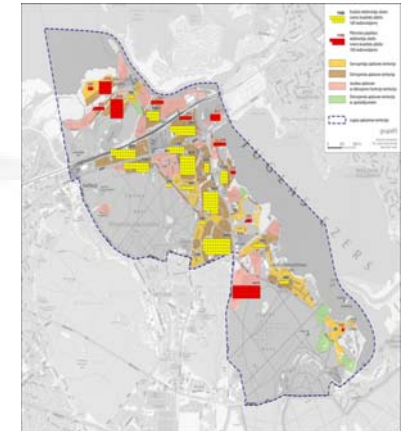

Pic.5, residential structure of Jugla: the current number of residents (yellow colour) and estimated inhabitant growth (red colour). One square denotes 100 people. [1]

2. Multi-apartment buildings (general information)

There are 196 multi-apartment buildings in Jugla. The associated land area in average is 2800m² for one multi-apartment building. 25 different building management companies function in Jugla, many of which are managers of only one or few buildings. 141 multi-apartment buildings (78%) are managed by SIA "Juglas nami" (since 2011 a part of the municipal building management company "Rigas namu parvaldnieks"); only 8 of multi-apartment buildings have apartment owner associations.

Almost all apartments privately owned. With an exception of 7% of multi apartment buildings where ovens are used, the multi-apartment buildings of Jugla are connected to the district heat supply system and the average heat consumption of these buildings is 212kWh/m² annually.

Years when buildings were put into operation vary from 1890 till 2005: most of them (68%) were put into operation from 1961 till 1970, 12% from 1951 till 1960, 8% till 1950, 13% after 1970. The multi-apartment buildings mostly (60%) have 5 floors, 10% have 12 floors; 15% have 2 floors. The average living space for an apartment is 45,6m².



Pic.6, typical multi-apartment buildings in Jugla

3. Energy supply (general information)

91% of all of heat energy of Riga district heating is produced in CHP cycle, in production of which mainly (97%) natural gas is used.

The district heat supplier in Jugla is JSC „Rigas Siltums“ which transfers, produces, distributes and sales district heat and covers 75% of all district heat demand in Riga.

The heat supplied by JSC “Rigas siltums” is mainly produced by AS “Latvenergo” combined heat and power plants TEC1 and TEC2 and a smaller CHP plant owned by SIA “Juglas jauda”.

Multi-apartment buildings in Jugla are mainly dictrict-heating consumers with few exceptions.

The total length of the district-heating grid in Jugla neighbourhood is 33km, 7km of which are the transmission grid and 26 km are the distribution grid.

The heat load of apartment buildings in Jugla in total is 75,7MW (36,4MW for hot water preparation, 38,6MW for space heating, 0,7MW for ventilation) and of public buildings - 12,8MW (2,5MW for hot water preparation, 8,6MW for space heating, 1,6MW for ventilation) which results in the total heat load of Jugla district heat consumers - 88,5MW, and the specific heat load density (MW per unit of heat distribution network length) - 3,4 MW/km.



Pic.7, Gas supply grid (above) and district-heat supply grid (below) in Jugla

Conclusions of SWOT analyses

Analyzing the current status of Jugla and the development perspectives of it as a residential neighborhood, SWOT analyses was used concluding the internal factors (strengths and weaknesses) and the external factors (threats and opportunities) for the three fields: urban development, multi-apartment buildings, energy supply. The conclusions and the problems detected are shown in this chapter.

1. Urban areas

(conclusions of SWOT analyses)

Strengths: the spatial composition of Jugla neighbourhood, which includes living quarters, institutional and commercial buildings and nature landscapes (woods and waters); the location of Jugla and the existing transport network all are very good prerequisites for future development of Jugla neighbourhood.

Weaknesses: the relatively long distance from the city center, the complex structure of the neighbourhood.

Opportunities: availability of the natural landscapes, the existing infrastructure and the good transport coverage if developed further can operate as basis for attraction of new inhabitants and working places in neighbourhood.

Threats: main role in future development of the neighbourhood Jugla is played by municipality of Riga, if financial and administrative resources for implementation of development actions are not allocated, the future development of the neighbourhood can be significantly endangered; if not developed the outdated public outdoor infrastructure, lack of parking places, could lead to further degradation of Jugla neighbourhood.

Problem P1.1 'Quality of the public outdoor space is low'

Many elements of the public outdoor space of Jugla neighborhood are outdated and quality of the public space in mostly low.



Pic.8, Strengths and opportunities: Jugla has institutional, commercial and residential buildings

Problem P1.1a 'Quality of the inner yards of the multi-apartment buildings is low'

The public infrastructure of high-rise multi-apartment building inner yards (greenery, children playgrounds, and outdoor elements) is morally outdated and does not meet the quality standards of today. [1].

Problem P1.1b 'Greenery, waterfronts and woods are underdeveloped'

Though Jugla is one of those neighbourhoods of Riga where the presence of green space and waters (rivers and lakes) can be felt most, the greenfields are mostly undeveloped, parts of woods and waterfronts are unapproachable and are not used to their potential.

Problem P1.1c 'The car parking places do not cover the demand'

Shortage of overnight parking places for cars of Jugla residents is an acute problem. Cars are often parked chaotically (even in greeneries) thus making inner yards of the neighbourhood visually more unattractive.

Problem P1.1d 'Public outdoor space in Jugla is not adjusted for hadicaped people'

The largest center for visually impaired persons of Latvia is located in Jugla (Jugla blind people village). Still only part of the public

outdoor space is suitable for visually impaired thus endangering inclusion of visually impaired people into society. There is also an urgent need for improvements of the outdoor space to make it easier accessible for other handicapped or old persons.

Problem P1.1f 'Visual quality of buildings is low'
Multi-apartment and also public buildings are not renovated in Jugla and in most cases look unattractive.

Problem P1.2 'Several territories available for development of Jugla have difficult usage conditions'

There are parts of Jugla territory that would theoretically be suitable for future development, for example construction of new objects, but cannot be used for that purpose because it would take large investments before the works can be started. These factors spatially limit the future development possibilities of Jugla.

Problem P1.2a 'Several territories have high groundwater'
Several of the territories that could be available for multi-apartment or detached building construction have high groundwaters.

Problem P1.2b 'The territories of Jugla around the lakes have a relatively high flood risk'

Due to the neighbourhood's geological situation, in part of the territory, especially around lakes, flood risk persists. It would take significant amount of resources to limit or prevent this risk fully.

Problem P1.2c 'Several territories of Jugla are degraded'

The former soviet time industrial zones and their surroundings in Jugla (former "Jugla manufacture" and "Rīgas audums" complexes) are either abandoned or used just partly. Complex solutions to include these degraded territories in urban environment are needed, however fragmented ownership and lack of resources can impede realisation of those solutions.



Pic.9, Strengths and opportunities: Jugla neighbourhood has a lot of green areas with huge development potential. [1]

Problem P1.3 'Spatial structure of Jugla is very complex'

Jugla is the second largest neighbourhood of Riga, but it is not compositionally unified. The neighbourhood is split into several historically developed parts with their local subcentres. A coordinated and integrated development of the whole territory has not been done.

Problem P1.3a 'Territory located above Riga-Vidzeme railway is not unified with the rest of Jugla'

Northern part of Jugla (*Makskernieku ciemats*, see Pic.11) is separated from the rest of the neighbourhood by Rīga-Vidzeme railway and Rīga-Vidzeme highway. In this part of Jugla there is not sufficient public transport coverage and the railway crossings are too few, which results in *Makskernieku ciemats* being functionally cut from the rest of Jugla.

Problem P1.3b 'Jugla has not a strong local centre'

A strong local centre of the neighbourhood does not exist but development of such a centre would be desirable.

Problem P1.4 'Social infrastructure of Jugla is not fully sufficient'

The existing social infrastructure in Jugla is only partly sufficient for the relatively high number of inhabitants (26 000).

Problem P1.4a 'The existing kindergartens in Jugla do not cover all the demand'

There are nine preschool facilities in Jugla, but they do not ensure kindergarten places for all children. According to standards, there should be five more kindergartens in Jugla neighbourhood.

Problem P1.4b 'Existing recreational possibilities do not cover all the demand'

There are few outdoor recreational possibilities in Jugla (walking paths through woods and besides waters) but none indoor. Jugla residents tend to use the recreational possibilities outside of Jugla, which also puts more stress on the already problematic transportation situation in the city.

Problem P1.5 'Several parts of Jugla are not accessible for some types of vehicles'

Though in general the transport system for Jugla is of a good quality (there are several tram, bus and minibus lines connecting neighbourhood to the city centre) the transport connections to parts of Jugla and bicycle paths should be still improved.

Problem P1.5a 'Public transport network does not cover Fishermens village in Jugla'

Maskernieku ciemats (see Pic.11), the northern part of Jugla, which Riga-Vidzeme railway cuts from the rest of the neighbourhood, is not covered by the public transport network of Riga at all. If not solved, this problem can lead to further separation of this area, especially if additional highway parallel to the railway is built in future.

Problem P1.5b 'Jugla is not covered by bicycle path network and lacks bicycle parking places'

Even though there is a recently constructed single bicycle path connecting Jugla to the city centre, the rest of the neighbourhood is not covered by bicycle path network and it is very inconvenient to reach other neighbourhoods by bicycle. The bicycle parking places are almost non-existent.



Pic.10, A feature of Jugla: a small village for visually impaired persons is placed in Jugla neighbourhood.

Problem P1.6 'Activity of residents of Jugla is low'

Activity of inhabitants regarding all issues concerning Jugla (solutions for the current problems or future development of the neighbourhood) is very low.

Problem P1.6a 'Jugla has not a distinguished identity in perception of its residents'

Currently, Juglas just like all the other neighbourhoods of Riga is perceived by residents only as a historical name of some part of the Riga city. Jugla does not have administrative borders or an administrative body. The neighbourhood does not have its own identity and as a result inhabitants do not identify themselves with the neighbourhood they live in.

Problem P1.6b 'Residents of Jugla show no initiative to improve their neighbourhood'

Inhabitants of Jugla are passive to show initiative or to express interest in issues related to development of their neighbourhood. This is especially true about the inhabitants of multi-apartment buildings.

Problem P1.7 'Economic activity is low in Jugla'

The economic activity (number of companies and workplaces, services provided, etc.) currently is low in Jugla neighbourhood.

Problem P1.7a 'Number of work places is too small in Jugla'

There are approximately 6 thousand persons employed within Jugla neighbourhood, which is considerably less than in other neighbourhoods of Riga or other cities in Latvia. More working places in the neighbourhood are needed.

Problem P1.7b 'Residents of Jugla have a low paying capacity'

The current economic situation of the country and the recent economy crisis result in a relatively low paying and purchasing capacity of inhabitants of Jugla.

Problem P1.7c 'Visitors and service users are not attracted to Jugla'

As there are almost no recreational facilities located in Jugla, neither large city-scale shopping centres nor other establishments of commerce or services (except the local scale shopping centre "Jugla centre"), visitors and service users from outside of Jugla are not being attracted to the neighbourhood. This does not facilitate longterm development of Jugla neighbourhood.



Pic.11, Territorial structure of Jugla: *Makskernieku ciemats* (the above, northern part of Jugla), territory around the main street of Riga where commercial and institutional buildings are placed (below *Makskernieku ciemats*), residential Jugla (in the center), Smerļa wood and Jugla wood (the two green areas) and the territories besides Jugla lake. [1]

2. Multi-apartment buildings (conclusions of SWOT analyses)

Strengths: the existing multi-apartment building stock provides accommodation to 95% of inhabitants of Jugla; operation of the building stock can be continued.

Weaknesses: quality of the buildings is often poor; apartment owner awareness of this and activity to solve the problems is low.

Opportunities: it is possible to solve the technical problems of buildings by renovation; it is also possible to develop an appropriate organizational and financial scheme that would overcome inhabitant lack of awareness.

Threats: the realization of a large-scale building renovation is not possible without political solution but the political awareness of the urgent need of renovation is still very low and hard to overcome; the technical condition of not renovated prefabricated panel buildings will deteriorate fast.

Problem P2.1 'Technical quality of multi-apartment buildings is low'

The technical condition of multi-apartment buildings in Jugla is poor. Building outer constructions and engineering systems have many defects. There are cracks on facades and in many cases old roofs, windows and doors cause high heat losses. The insulation on hot water and heating pipes is old and uneven, ventilation shafts in many cases are not cleaned and ventilation intensity is low. The balconies are deteriorated. Though the northern end walls of several buildings have been insulated, the insulation is not continued.

Problem P2.2 'Quality of indoor climate in apartments is very low'

Quality of the indoor climate inside apartments of multi-apartment buildings is determined by three main parameters: air temperature,



Pic.12, Loggia of a 12-floor multi-apartment building in Jugla [2]



Pic.13, intensive heat losses (a multi-apartment building in Jugla). [2]



Pic.14, clean ventilation shafts (multi-apartment building of series No.464). [7]



Pic.15, ventilation shaft with a construction defect (multi-apartment building of series No.464). [7]

air humidity and CO2 concentration in the air. All of these parameters are affected by: outside air temperature, outside air humidity, ventilation intensity, heating intensity. In the survey [7] it has been concluded that only one third of apartments have adequate indoor climate. It has to be noted that also presence of pets in apartments, especially, cats and dogs, significantly lowers air quality. [7].

Problem P2.2.a 'Air humidity in apartments is often too low or too high'

Physiologically normal indoor air humidity is 50%. Practically it strongly depends on season and ventilation intensity. During wintertime in those apartments where ventilation intensity is adequate (one third of cases, typically the upper floor apartments where windows are held reclined all winter) the air humidity is 20%-30%. In those apartments where ventilation intensity is close to zero (two thirds of cases, ventilation airways in bathrooms are blocked) the air humidity in apartments is 50%-60%, which is too high for wintertime and causes mould formations. In the existing multi-apartment buildings with natural ventilation in wintertime, only air humidity in the range of 30%-40% can be considered as normal. In summertime in most cases windows are held open and indoor air humidity is in the range of 50%-70%, which can be considered normal for summertime [7].

Problem P2.2.b 'CO2 concentration in apartments is often extremely high'

Air with CO2 level above 1500ppm (0.15%) is very unhealthy. CO2 concentration of outside air is approximately 400-500ppm (0.04%-0.05%). If CO2 concentration in the indoor air is up to 800ppm (0.08%) air can be considered fresh, if it is higher ventilation should be started. In wintertime 40% of apartments have the average CO2 concentration of approximately 1000ppm (0.1%), the rest have the average CO2 concentration higher, in several cases it even reaches 2000ppm (0.2%) and 3000ppm (0.3%). This problem is mainly caused by people preferring warmer not fresher air. In summertime in most cases CO2 level is adequate, because apartment windows are held open most of the time. [7]

Problem P2.2.c 'Inside air temperature in apartments often is too low or too high'

Temperature in the range of 20°C-22°C for most people is a normal comfort temperature. In multi-apartment buildings in most cases the

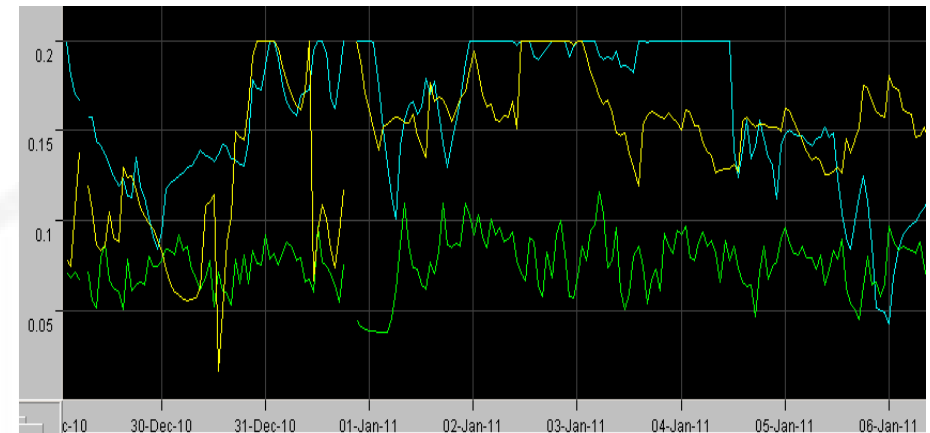

Pic.16, CO2 concentration measurements in bedrooms of three apartments during a heating season, green line - adequate air exchange (both ventilation shafts are clean), yellow line - inadequate air exchange (ventilation shaft in kitchen is blocked), blue line - inadequate air exchange (ventilation shafts in kitchen and bathroom are blocked). [7]

apartments at the end walls and on the ground floor have lower air temperature (below 18°C) but the apartments placed in the middle of the building have normal inside temperature (22°C). In several cases the inside temperature of upper floor apartments is too high.

Problem P2.3 'Heat energy consumption of multi-apartment buildings is very high'

In Jugla the average annual heat consumption per 1m² of heating space of multi-apartment buildings is 212 kWh/m². The total heating space of multi-apartment buildings in Jugla is 458 thm². The total annual heat energy consumption is 97 GWh, 83 GWh of which are consumed by space heating and 14 GWh - by hot water preparation. The total annual cost of heat energy in Jugla is 4,3 mil LVL (3 mil EUR). (See, document [2]).

Problem P2.4 Apartment owners do not realize the necessity of renovation, do not believe that quality can be ensured and do not trust private building managers

One of the most important obstacles to start a large-scale building renovation in Jugla (also in Riga and Latvia) is the general negative attitude towards construction works due to the low reputation of all construction industry. The dominant opinion is that construction companies are not able to ensure quality of construction works, which in case of building renovation would directly affect the amount of saved heating energy. [2], [8], [9].

Problem P2.5 Apartment owners are not able to renovate their buildings and ensure quality of renovation

The previous building renovation practice cannot be carried out on a large-scale mainly because the current procedure depends on apartment owner knowledge on organizational, financial and construction works. As the statistics of the existing renovation projects show this knowledge by apartment owners is acquired very slowly.

Problem P2.5.a Apartment owners lack experience and knowledge on decision-making

The apartment owners of multi-apartment buildings in most cases lack experience and knowledge of decision-making process in apartment owner meetings.

Problem P2.5.b Apartment owners lack experience and knowledge on management of their buildings

The apartment owners of multi-apartment buildings and the elected members of the board of the apartment owner association in most cases lack the experience and knowledge on management of their building (bookkeeping, attraction of investments).

Problem P2.5.c Apartment owners lack experience and knowledge on organization of building renovation

The apartment owners of multi-apartment buildings and the elected members of the board of the apartment owner association in most cases lack the experience and knowledge on management and realization of building renovation process.

Problem P2.6 'The current approach to building renovation does not ensure high quality of renovation'

The current approach to organization and realization of multi-apartment building renovation does not provide renovation quality up to the standards of European countries; it ensures only reduction of heat losses through building facades but does not ensure reduction of heat losses around window frames, through attics, cellars and ventilation system.

Problem P2.6a 'Measures, that do not improve building energy efficiency but are urgently needed, are not included in renovation'

In many cases those measures that do not improve building energy efficiency (such as renovation of buildings electricity supply system, cold water system, sewerage system) are not included in renovation, because these measures are not co financed by the existing renovation support programs. This often leads to absurd situations where, for example, the old hot water pipes are replaced by new ones but the old cold water pipes remain.

Problem P2.6.b 'The normative acts do not state that renovation of ventilation system is a mandatory part of building renovation'

Currently the normative acts that define building renovation do not state renovation of ventilation systems as binding. As a result of this, in almost all renovated buildings ventilation systems are not renovated at all and the air exchange and indoor climate quality in apartments is not ensured up to the normative standards.

Problem P2.6.c 'Energy efficient building renovation solutions are not in accordance with the current fire-prevention standards'

The existing fire-prevention norms are not developed from the building energy efficiency point of view. The fire prevention solutions included in the norms are not energy efficient, which especially is an issue when high-rise (12 to 16 floor, see Pic.17) buildings are renovated.



Pic.17, 12-floor multi-apartment buildings in Jugla

Problem P2.7 'The current financial schemes for building renovation do not promote renovation'

The current renovation financing system is ineffective mostly due to the fact that it relays on the apartment owner ability to deal with all financial issues of renovation.

Problem P2.7.a Apartment owners cannot cover renovation expenses from their savings

The major part of apartment owners does not tend to make private savings and are not ready to make investments in their own building; many buildings have communal payment debts thus also the savings of building apartment owner associations, which are formed, from apartment owner monthly payments are in most cases low or non-existent at all.

Problem P2.7.b Apartment owners are not willing to take bank loans

Especially due to the economy crises apartment owners fear to take bank loans for building renovation, as they are not sure if they will be able to pay it back.

Problem P2.7.c Significant part of apartment owners has a very low paying capacity

There is a significant part of apartment owners with very low income who in many cases also have communal debts and cannot afford investments in their building. This part of apartment owners blocks other apartment owner initiative to renovate building. If a support mechanism is not found this problem will persist.

3. Energy supply (conclusions of SWOT analyses)

Energy supply for Jugla neighborhood has been analyzed as a part of Riga energy supply.

Strengths: good current technical condition of combined heat and power (CHP) plants and district heating grid; almost 90% of heat energy is produced in CHP cycle and 100% of electricity is produced in CHP cycle; the district heating grid renovation process is going according to the graphic, external pipe-works are replaced with pre-insulated pipes; during the last decade heat losses in grid have been reduced by more than a half and are now stabilized at 13% which is an appropriate level for an up to date city district heating system; security of both heat and electricity supply is high in Jugla due to several CHP plant connections to heat and electricity transmission networks.

Weaknesses: due to the growing electricity demand in Riga and Jugla it might not be possible to significantly increase the share of electricity produced by renewable energy sources (RES).

Opportunities: the existing natural gas storage infrastructure in Latvia is uniquely appropriate for energy resources storage in a gas state; the existing natural gas transmission grid will be available after Year 2014 for all gas producers and suppliers, including those who produce and supply sufficiently qualitative gas fuel produced using RES.

Threats: the current share of natural gas use makes energy production dependant on gas supplier; the increase of natural gas costs in Latvia has reached 400% in the recent decade and the increase of heat tariff has reached 260% in Riga.

Problem P3.1 'The share of renewable energy sources in energy production of Riga is low'

In Riga opportunities to use renewable energy sources in short term are restricted. Currently the share of fossil fuel in energy production in Riga is very high; the share of natural gas use in the CHP plants is close to 100%. Six fold growth of biomass fuel consumption in the district heating of the left bank of the river Daugava has been estimated in the 'Riga Sustainable Energy Action Plan 2010-2020', thereby achieving economically justified size of RES in this part of the district heating system. Whereas in the recently updated natural gas-fired CHP plants, fuel diversification has neither technical nor economical basis, therefore biogas or synthetic gas use in the future should be considered.

Problem P3.1a 'Biogas currently is used only locally'

Currently the existing natural gas distribution network is not available for biogas production facilities; therefore biogas is being produced only locally for energy production in local CHP plants, for example Daugavgrīva, Getliņi.

Problem P3.1b 'Integration of biogas and natural gas distribution networks is not possible currently'

The existing natural gas distribution network is suitable for storage and supply of appropriately qualitative biogas and synthetic gas (RES), however biogas feed in to the natural gas grid will not be possible before the gas market opening. After the year 2014 renewable gas feeders will be allowed by state regulations, but at the beginning biogas production, treatment and network connection to the grid might not be cost-effective.

Problem P3.1c 'Use of fossil fuel creates CO2 emissions'

Use of fossil fuel creates CO2 emissions, which increase risk of climate changes.

Problem P3.2 'Use of fuel for energy production in local heat sources creates air pollution'

In Riga concentration of mechanical particles in the air frequently exceeds the normative values for both 24 hour and yearly scales (data of 'Riga city air quality improvement action program 2011-2015'). Transposition of requirements of EU Directive 2010/31/EU "Building energy efficiency directive (recast)" regarding inspections of small boilers and ventilation systems of buildings is still in the process in Latvia and Riga. Thus quality control of local fuel incineration and of heating devices in buildings is delayed, which does not promote reduction of mechanical particle air pollution.

Problem P3.2a 'Use of fuel for energy production in local heat sources creates NO_x pollution in air'

Use of fuel for energy production in local heat sources creates air pollution by NO_x and increases its concentration over background level.

Problem P3.2b 'Use of fuel for energy production in local heat sources creates mechanical particle pollution in air'

Use of fuel for energy production in local heat sources creates air pollution by mechanical particles increases its concentration over background level.

Problem P3.2c 'Technology for cleaning of flue gases and NO_x reduction are not commonly used for small scale local burners, boilers and ovens'

Technology for NO_x reduction and flue gas cleaning are not commonly used for small-scale local burners, boilers and ovens. Appropriately qualitative equipment for treatment of burners and flue gas are tailored for district heating system heat plants mostly.

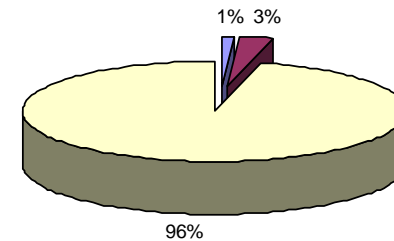

Pic.18, Share of Jugla heat loads in Riga district heating system: yellow - consumers of other neighbourhoods, brown - multi-apartment buildings of Jugla, blue - other consumers of Jugla

Problem P3.3 'Reduced heat demand due to buildings renovation can affect efficiency of the city energy supply'

Heat demand for space heating reduces due to the energy efficient renovation of multi-apartment buildings, approximately 97% (Jugla) of consumed heat energy is produced in combined heat and power cycle. A large-scale multi-apartment building renovation in Riga might affect efficiency of energy supply system, but in a case when only multi-apartment buildings in Jugla are renovated the impact on the energy supply system of Riga would not be relevant (see Pic.18).

Problem P3.3a 'Reduced heat load reduces the efficiency of cogeneration'

If new consumers of newly constructed buildings are not connected to the district-heating grid, reduction of the existing heat loads might reduce both efficiency of cogeneration and heat loads of CHP plants. This problem is absent in the base (see Pic.19) and the optimistic city development scenarios. In the base scenario new heat loads due to new building construction fully covers reduction of heat loads reduction due to energy efficient renovation of buildings. In a city development scenario where building construction rate is less than in the base scenario (see Pic.20), the reduced CHP efficiency can lead to increase of operational costs of energy production.

Problem P3.3b 'Reduced heat loads may reduce efficiency of district heating networks'

In a city development scenario where building construction rate is less than in the base scenario reduced heat loads lead to higher relative losses in district heating networks, thus slightly increasing the heat supply costs.

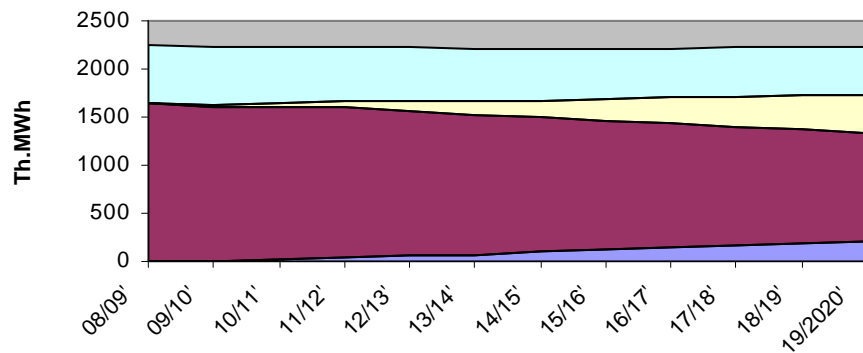

Pic.19, Forecast of heat consumption by district heating system in Riga from CHP plants TEC1 and TEC2: base scenario where heat consumption reduction by building renovation is fully compensated by new heat loads. (Light blue area - the existing public buildings; Yellow area - new public buildings; Brown area - the existing multi-apartment buildings; Dark blue area - new multi-apartment buildings.)

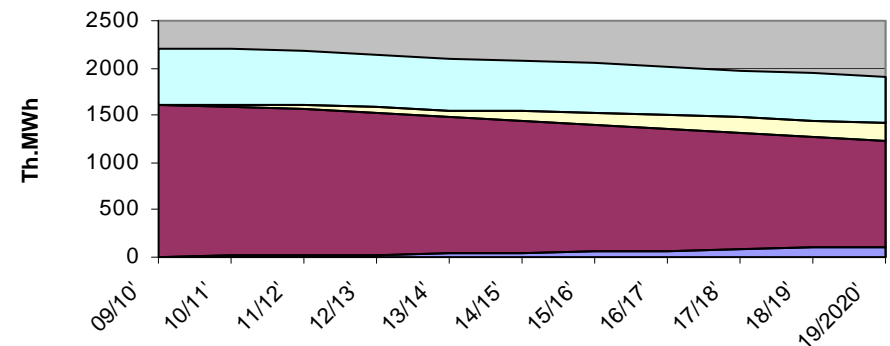

Pic.20, Forecast of heat consumption by district heating system in Riga from CHP plants TEC1 and TEC2: a scenario where heat consumption reduction by building renovation is not compensated by new heat loads. (Light blue area - the existing public buildings; Yellow area - new public buildings; Brown area - the existing multi-apartment buildings; Dark blue area - new multi-apartment buildings.)

Development actions

1. Urban areas

(development actions)

In this chapter the activities to help solving the problems listed in chapter “Urban areas (conclusions of SWOT analyses)” are given. These activities also would contribute in reaching two aims of the “Riga long-term development strategy till the year 2025”: Priority Aim PA4 ‘Life in a city with qualitative neighbourhoods’ and its tasks; Strategic Aim SA10 ‘Green city with good environmental quality’ and its tasks.

Activity A1.1 Provision of overnight parking places for multi-apartment building inhabitants

[Responsible institutions - District administration of Riga City Council; Municipal company “Rīgas satiksme (Riga traffic)”; Traffic Department of Riga City Council]



Pic.21, The planned Facilitation of Strazdupite river

In the frame of *Urb.Energy* project solutions for car parking spaces in several inner yards of multi-apartment building blocks were prepared [1] (see, Pic.22). This activity would help solving problems P1.1a, P1.1c.

Activity A1.2 Reconstruction of the existing greenery and creation of additional greeneries

[Responsible institutions - Municipal agency “Rīgas dārzi un parki (Gardens and parks of Riga)”]

In the frame of *Urb.Energy* project as a part of the document [1] an activity to upgrade the riverside of Strazdupite is

planned. This would improve the accessibility of the territory by constructing new pedestrian crossings (bridges) over the river and would facilitate the open public space by developing footpaths along the river establishing a convenient connection between Juglas st. and Murjanu st. for pedestrians and cyclists (see Pic.21). This activity would help solving problems P1.1b, P1.4b, P1.7c.

Activity A1.3 Improvement of inner yards of multi-apartment buildings’

[Responsible institutions - Housing and Environment Department of Riga City Council; Municipal agency “Rīgas dārzi un parki (Gardens and parks of Riga)”; Municipal agency “Rīgas gaisma (Lights of Riga)”]

Reconstruction of greenery, benches, lightning infrastructure and provision of small architecture forms and other public outdoor elements would improve the inner yard quality in Jugla. This activity would help solving problems P1.1a, P1.1b.

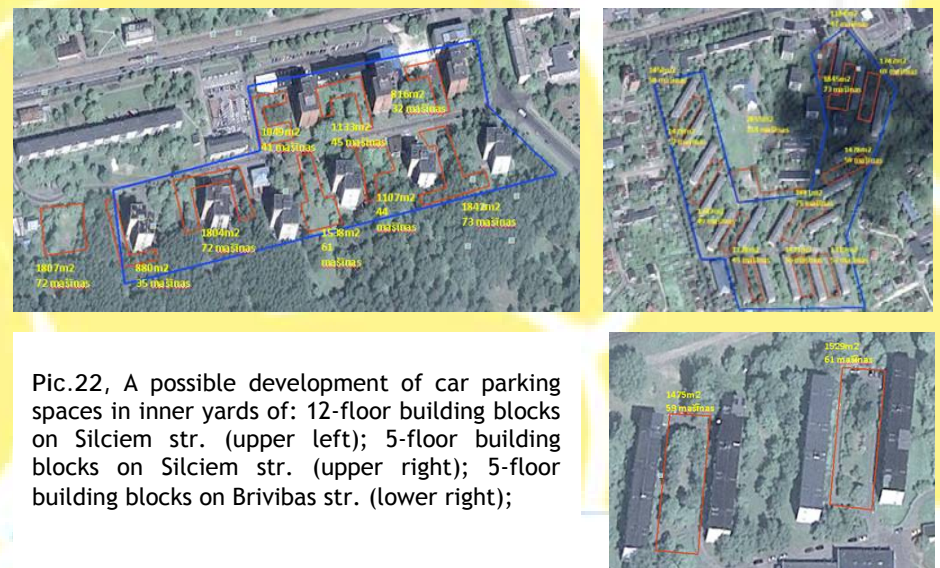

Pic.22, A possible development of car parking spaces in inner yards of: 12-floor building blocks on Silciem str. (upper left); 5-floor building blocks on Silciem str. (upper right); 5-floor building blocks on Brivibas str. (lower right);

Activity A1.4 Adaptation of street infrastructure for handicapped people

[Responsible institution - Traffic Department of Riga City Council]

Adaptation of street infrastructure for handicapped people especially blind people is necessary in Jugla. It would help solving problem P1.1d.

Activity A1.5 Revitalization of former industrial zones and brown field sites

[Responsible institution - City Development Department of Riga City Council]

Revitalization of the degraded territories in Jugla would help solving problems P1.2a, P1.2c, P1.7.

Activity A1.6 Improvement of Jugla Lake waterfront

[Responsible institutions - District administration of Riga City Council; Housing and Environment Department of Riga City Council]

In the frame of *Urb.Energy* project as a part of the document [1] an activity to facilitate the lakeshore of Jugla lake was prepared. Estimation of the total costs are 475 th.LVL (334 th.EUR). This activity would help solving problems P1.2b, P1.4 b, P1.7c.

Activity A1.7 Construction of additional kindergartens

[Responsible institutions - Education, Youth and Sports Department of Riga City Council; Property Department of Riga City Council]

Additional five kindergartens are necessary in Jugla to help solving problem P1.4a.

Activity A1.8 Development of recreation possibilities in woods

[Responsible institutions - Municipal company "Rīgas meži (Riga woods)" of Riga City Council]

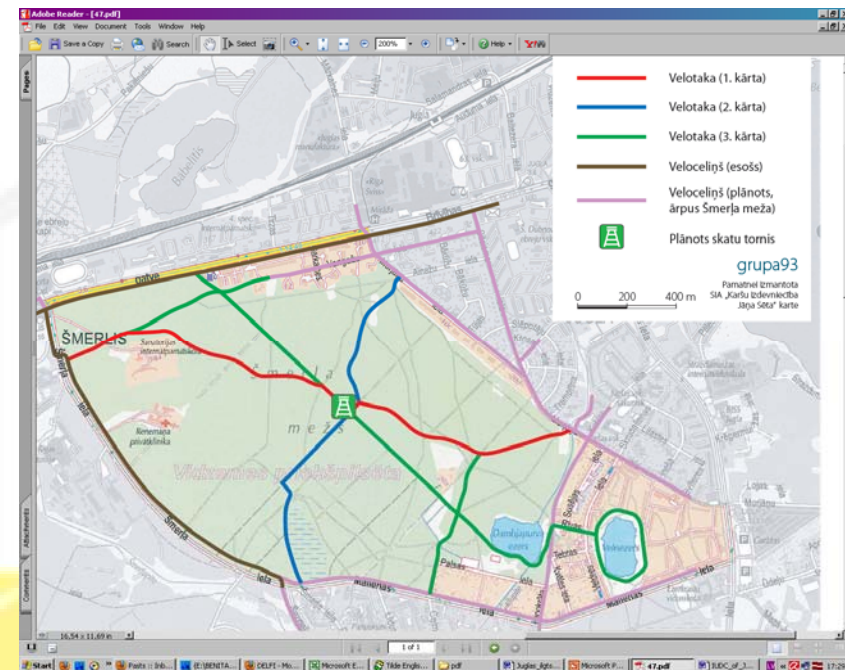

Pic.23, The planned cycling and skiing path in Smerlis wood, development in three stages: Stage 1 (red line) 2300m section from Šmerļa str. to Murjanu str.; Stage 2 (blue line) 1500m section from the middle of the Šmerļa str. to Ainazu str; Stage 3 (green line) 4200m section from Brivibas str. to Rivas str. and a circle around *Velnezers* lake.

In the frame of *Urb.Energy* project as a part of the document [1] an activity for construction of cycling and skiing path in Smerlis wood was elaborated. This recreational paths is planned through the Smerlis wood, 8km in total length and covered by natural surfacing (granite chips). The path could be used for skiing during wintertime and for cycling during summertime. The estimated costs are 32 th.LVL (46 th.EUR), construction of the path could be carried out in three stages (see Pic.23). This activity would help solving problems P1.1b, P1.4b, P1.7c.

Activity A1.9 Construction of additional pedestrian crossings

[Responsible institution - Traffic Department of Riga City Council]

This activity would help solving problem P1.1.

Activity A1.10 Improvement of sidewalks and bicycle paths

[Responsible institution - Traffic Department of Riga City Council]

This activity would help solving problems P1.1, P1.3a, P1.5b.

Activity A1.11 Provision of bicycle parking facilities

[Responsible institution - Traffic Department of Riga City Council]

This activity would help solving problem P1.5b.

Recommendations for development actions for urban areas in Jugla:

- R1.1 As a part of Riga neighbourhood spatial planning development of strong neighbourhood centres should be considered (also in Jugla);
- R1.2 To elaborate a neighbourhood transport and parking concept to ensure sustainability of overnight parking for multi-apartment building inhabitants;
- R1.3 The functions of District administration of Riga City Council should be extended to overtake the responsibility of issues related to city district development and realization of cross structural urban development projects;
- R1.4 Part of income from City infrastructure development fund should be redirected on development projects in neighbourhoods;
- R1.5 Improvements of inner yards of multi-apartment buildings should be carried out according to the elaborated visual identity of Jugla;
- R1.6 Adoption of infrastructure for blind people should be done in cooperation with Latvian Blind People Society;
- R1.7 To elaborate a programme of terms and conditions for investment attraction to ensure high quality revitalization of brown fields for future neighbourhood development, public infrastructure for these sites should be provided by Municipality;
- R1.8 Municipality should provide support to local companies for start-up, possibly by transforming tasks and objectives of the existing grant program "Atspēriens (Take-off)";
- R1.9 A 'Neighbourhood initiative fund' should be created in order to facilitate inhabitant involvement in local development processes.

Activity A1.12 Construction of additional railway crossing for pedestrians

[Responsible institution - Traffic Department of Riga City Council]

Additional railway crossing for both cars and pedestrians are necessary in Jugla. In the frame of *Urb.Energy* project as a part of the document [1] activities for development of Auduma street (2,2km) and construction of pedestrian crossing over railway were elaborated. The activities would help solving problems P1.3a, P1.5a.

Activity A1.13 Organization of inhabitant involvement in neighbourhood development processes

[Responsible institution - District administration of Riga City Council]

Organization of campaigns and events targeted to increase involvement of inhabitants in neighbourhood development processes is necessary to help solving problem P1.6b.

Activity A1.14 Promotion of Jugla visual identity

[Responsible institution - District administration of Riga City Council]

To solve the problem that Jugla has not a distinguished identity (problem P1.6a) in perception of its residents in the frame of *Urb.Energy* project the visual identity for multi-apartment building blocks after renovation and also a logo of Jugla neighbourhood were prepared (see Pic.24).



Pic.24, Logo of Jugla, developed as a part of Jugla visual identity [6].

2. Multi-apartment buildings (development actions)

In this chapter the activities to help solving the problems listed in the chapter “Multi-apartment buildings (conclusions of SWOT analyses)” are given. These activities also would contribute in reaching two aims of the “Riga long-term development strategy till the year 2025”: Priority Aim PA4 ‘Life in a city with qualitative neighborhoods’ (Task T4.5 ‘Improvement of the visual and aesthetic quality of the neighborhoods of the city’) and Strategical Aim SA12 ‘A city with qualitative dwellings’ (Task T12.3 ‘Promotion of renovation and facilitation of privately owned buildings’, Task T12.7 ‘Promotion of rational use of heat and electricity in dwellings’).

Activity A2.1 ‘Renovation of multi-apartment buildings in Jugla’

[Responsible institution - Riga City Council]

Renovation of multi apartment buildings depending on the measures applied would solve most of the problems related to building poor technical condition (Problem P2.1), low indoor climate quality (Problem P2.2) and also would reduce the heat energy consumption (Problem P2.3). In the frame of *Urb.Energy* project three renovation programs (minimal, medium, maximal) with different costs and saving potentials were prepared. Several recommendations on organizational and financial issues (R2.2-R2.10, R2.16-R2.19) and technical issues (R2.1, R2.11-R2.15) were given [2] and a sample renovation design for a multi apartment building of series No.464 was prepared [5].

Three multi-apartment building renovation programs [2]:

1.program (minimal): insulation of outer constructions, and replacement of the old windows with new ones, according to the requirements of the building code LBN002-01. The possible reduction of heat consumption for the 1.program is up to **50%**. Estimated costs - 65 LVL/m² (93 EUR/m²)

2.program (medium): all the measures of the first program and also reconstruction of the heating system, implementation of thermo regulators (gives additionally 10% savings) and implementation of an energy efficient ventilation system (gives additionally 10% savings). The possible reduction of heat consumption for the 2.program is up to **70%**. Estimated costs - 94 LVL/m² (134 EUR/m²).

3.program (maximal): all the measures of the second program executed on the level that meets requirements of low energy buildings: insulation of outer constructions app.25cm, renovation of the heating system, implementation of energy efficient ventilation systems. The possible reduction of heat consumption for the 3.program is up to **85%**. Estimated costs - 132 LVL/m² (189 EUR/m²).

Recommendations for the Activity A2.1 ‘Renovation of multi-apartment buildings in Jugla’ [2]:

R2.1 To renovate buildings according to the 3.program to reach the maximum heat energy savings, thus helping to achieve the requirements of EC directive on energy performance of buildings and reducing renovation costs later.

R2.2 To finance large-scale multi-apartment building renovation in Riga a financial instrument – Revolving Fund – should be established.

R2.3 Multi-apartment building renovation should be organized by the Municipality.

R2.4 Renovation costs should be reduced by carrying out the renovation for groups of buildings.

R2.5 Only companies with established company’s quality management system should be chosen for management of renovation and realization of the construction works.

Activity A2.2 'Preparation of a one, unified product *building's renovation* that can be easily understood by the apartment owners'

[Responsible institution - Riga City Council]

Apartment owners are not specialists in management of construction works and attraction of financing, they lack experience and knowledge on building management and building renovation, which leads to the situation that apartment owners on their own are not able to renovate their buildings and ensure the quality of renovation (Problem P2.5). Building renovation should be carried out by professionals and apartment owners should buy building's renovation as a service. A single easy to comprehend product "building renovation" should be prepared and offered to apartment owners [2] (see recommendations R2.6 -R2.8, R2.16-R2.19). This would also help to overcome the obstacle that apartment owners do not believe that renovation quality can be ensured (Problem P2.4). (See scheme in Pic.25).

Activity A2.3 'Supplementation of the normative acts with a statement that renovation of ventilation system is a mandatory part of building renovation'

[Responsible institution - State government]

In the normative acts, in which building renovation is defined, it should be stated that renovation of ventilation systems and ensuring of normative air exchange in all apartments is mandatory. As the surveys carried out in the frame of *Urb.Energy* project [2] and [7] show, costs of ventilation system and air exchange renewal are relatively very low - approximately 20LVL (30EUR) per apartment, which make only 2% of the average renovation costs per apartment. This activity would solve problem P2.6b and would improve renovation quality.

Recommendations for the Activities A2.1 'Renovation of multi-apartment buildings in Jugla' and A2.2 'Preparation of a one, unified product *building's renovation* that can be easily understood by the apartment owners' [2]:

R2.6 In the contract between apartment owners and the company that realizes the renovation, a point should be included that the energy savings stated in energy audit must be reached in the result of renovation.

R2.7 When the decision to carry out renovation is made the apartment owners should make a mutual contract about the usage of the common property and register that in the Land book stating the monthly payments as an obligation.

R2.8 To avoid any additional construction works and additional costs the technical design must be developed very detailed.

R2.9 During realization designer and field supervision should be ensured.

R2.10 To prepare a standardized renovation technical design for all series of buildings where glazing of all loggias is included.

R2.11 Instead of insulation of cellar ceiling the cellar floor should be insulated.

R2.12 Instead of insulation of attic floor the roof of the building should be insulated.

R2.13 Installation of new windows should be done in the wall insulation area.

R2.14 To prepare a detailed technical design of the ventilation system with heat recovery and realize it.

R2.15 Balconies of the 5-storey multi apartment buildings should be dismantled.

R2.16 In the order of the renovation's technical design the conclusions of the energy audit and the technical inspection should be included as binding.

R2.17 It should be emphasized that after renovation the visual quality of the building and facilitation of the area will be significantly higher.

R2.18 The construction works should be realized in such a way that monthly payment for the renovation would be less or equal with the monthly payment for the saved heating energy.

R2.19 The monthly payments should be set the same each month over a period of one year and at the end of each heating season a recalculation of the new monthly payment should be done (to significantly save administration costs)

Activity A2.4 Integration of fire-prevention standards and energy efficient building renovation solutions'

[Responsible institution - State government]

It is necessary to integrate the existing energy efficient building renovation solutions and the fire-preventing standards. Additionally, a section "energy efficient fire-protection solutions" should be provided in energy audit reports. This activity would solve problem P2.6c and would help to ensure better quality of building renovation for high-rise buildings.

Activity A2.5 'Organization of training courses for construction work supervisors and construction workers about the building renovation technologies and organizational issues'

[Responsible institution - Riga City Council]

This activity would help to ensure a better quality of multi-apartment building renovation (Problem P2.6).

Activity A2.6 'Development of a common visual image (visual identity) for the blocks or groups of multi-apartment buildings after renovation in Jugla'

[Responsible institution - Riga City Council]

This activity would help apartment owners to realize the necessity of building renovation (Problem P2.4) and also would improve the overall quality of renovation (Problem P2.6) by preparing common visual solutions for building groups. In the frame of *Urb.Energy* project a visual identity for three multi-apartment building groups in Jugla was prepared, document [6].

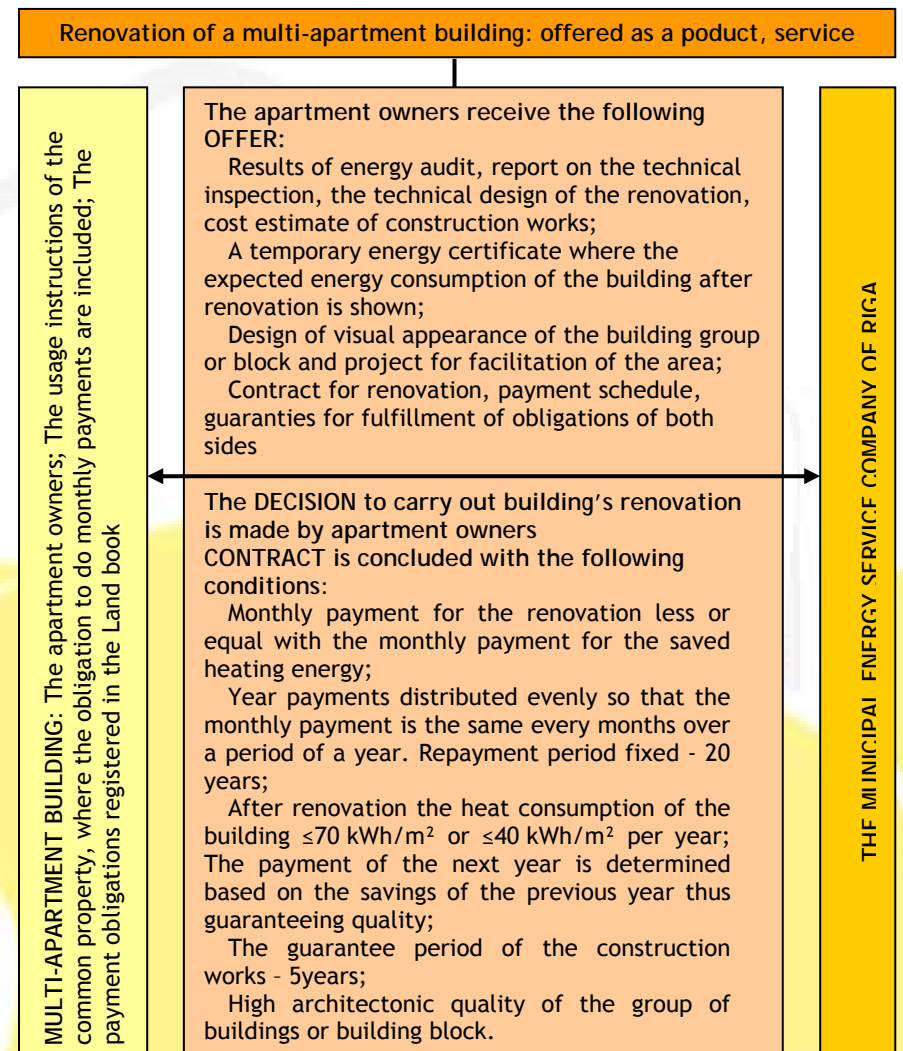

Pic.25, Conditions for receiving a positive decision on multi-apartment buildings renovation from apartment owners: offering the service of multi-apartment building renovation as a prepared product. [2]

3. Energy supply *(development actions)*

In this chapter the activities to help solving the problems listed in the chapter “Energy supply (conclusions of SWOT analyses)” are given. These activities also would contribute in reaching two aims of the “Riga long-term development strategy till the year 2025”: Strategical Aim SA10 ‘Green city with good environmental quality’ (Task T10.5 ‘Improvement of air quality’) and Strategical Aim SA12 ‘A city with qualitative dwellings’ (Task T12.7 ‘Promotion of rational use of heat and electricity in dwellings’).

Activity A3.1 ‘Restriction of construction of local heat sources in city areas where NO_x and mechanical particle concentration in air is high’

[Responsible institution - Riga City Council, Ministry of environmental protection and regional development]

In those city areas where NO_x and mechanical particle pollution level is high, construction of new local heat sources where energy is produced by fuel incineration is undesirable and should be restricted. This activity would help solving problem P3.2.

Activity A3.2 ‘Connection of local heat source consumers to the district heating system’

[Responsible institution - Riga City Council, Ministry of environmental protection and regional development]

To reduce the local NO_x and mechanical particle pollution in air and to raise heat loads of heat production in CHP cycle, shutting down of the local heat sources and connection of the consumers to the district heating system should be promoted. This activity would help solving problems P3.2 and P3.3.

Recommendations for the activity A3.3 ‘Raise of energy production efficiency’:

R3.1 Implementation of technologies for utilization of low potential heat of flue gases should be promoted for the centralized heat sources where only heat is produced.

R3.2 In the thermal power stations absorption heat pumps should be used to utilize the thermal energy unused in cogeneration process.

R3.3 In the existing industry and electricity production facilities, heat energy of low potential heat carrier (85°C-130°C) should be utilized for electric energy production by implementation of Organic Rankine Cycle technology.

Activity A3.3 ‘Raise of energy production efficiency’

[Responsible institution - Riga City Council, Ministry of environmental protection and regional development]

The heat energy unused in manufacturing industry and energy production processes should be utilized for production of additional heat and electric energy without fuel incineration in order to raise efficiency of city energy production in a case of heat load reduction. This activity would help solving problem P3.3, see also recommendations.

Activity A3.4 ‘Increase of biogas production and use after the gas supply market liberalization’

[Responsible institution - Riga City Council, Ministry of environmental protection and regional development]

In long term, biogas and fossil fuel (natural gas) networks should be integrated on state level in Latvia. For example, in Germany the networks are integrated and 3% of state gas consumption are

covered by biogas (data obtained in the frame of *Urb.Energy* project). After liberalization of gas market in Year 2014 the amount of produced biogas should be increased for feeding in the existing gas distribution and storage infrastructure; thus raising the share of RES used in energy supply of Riga. This activity would help solving problem P3.1.

Activity A3.5 'Increase range of available renewable energy sources for heat and electric energy production'

[Responsible institution - Ministry of Economics, Ministry of environmental protection and regional development, Riga City Council]



Pic.26, Absorption heat pump in CHP plant "Imanta" in Riga

The following renewable energy sources can be potentially used: waste incineration, biomass, use of heat pumps in heat supply system; use of sewage water heat; solar and geothermal energy. A pilot project should be carried out to survey use of these RES (in accordance with the 'Riga Sustainable Energy Action Plan 2010-2020') and to study the experience of other countries. This activity would help solving problem P3.1, see also recommendations.

Recommendations for the activity A3.5 'Increase range of available renewable energy sources for heat and electric energy production':

R3.4 The geothermal energy can potentially be used in Riga, a survey project should be carried out.

R3.5 To increase the share of RES in the existing energy supply system that is currently based on the fossil fuel (thermal power stations, gas networks, storage facility) in Latvia and also in Riga synthetic gas could be used. Synthetic gas can be produced by utilisation of CO₂, water and wind and solar power used for extra electricity production. This would also allow to completely use wind and solar energy. After liberalization of gas supply market in Year 2014 in long term it is possible to produce and to integrate synthetic gas in the existing gas supply network and the underground storage facility similarly to the *solarfuel* pilot project in Germany.

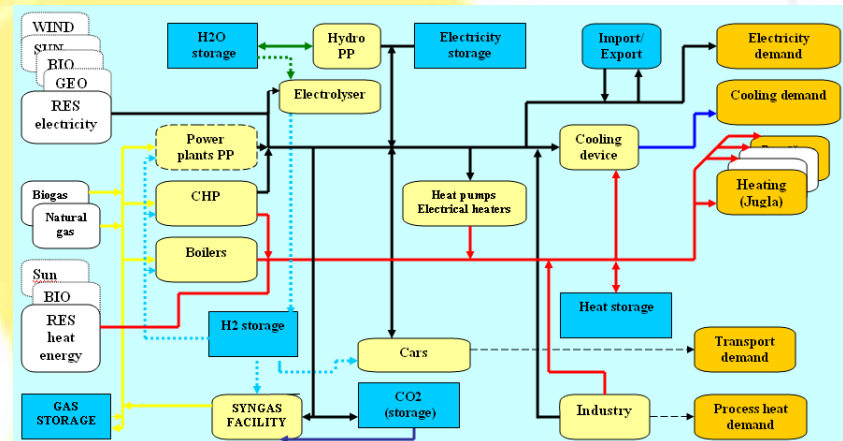

Pic.27, Scheme of possible development of energy supply system of Riga

Financing and organization

1. Urban areas

(financing and organization)

Implementation of activities A1.1-A1.14 and solving of problems P1.1-P1.7 (chapters “Urban areas (development actions)”, “Urban Areas, (conclusions of SWOT analyses)”) is possible if organizational and financial solutions described below are applied.

Organizational Activity O1.1 ‘Inclusion of integrated urban development approach in planning of Riga neighbourhoods’

[Responsible institution - City Development Department of Riga City Council]

To ensure integrated development of Riga it is necessary that Riga City Council elaborates, approves and implements integrated neighbourhood development concepts for all neighbourhoods of Riga. The forthcoming Riga City Development Plan should be amended to include integrated urban development approach to provide a framework for dealing with city level issues.

Organizational Activity O1.2 ‘Establishment of a structural unit responsible for integrated development of neighbourhoods’

[Responsible institution - Riga City Council]

Some changes in the organizational structure of municipality of Riga City are necessary. A structural unit within municipality should be appointed to take responsibility for integrated development of the city and particular neighbourhoods. In case of Jugla neighbourhood in accordance with the recommendation R1.2 (‘The functions of District administration of Riga City Council should be extended to overtake the responsibility of issues related to city district development and realization of cross structural urban development

projects’) this unit could be Riga Eastern Executive Board (*Rīgas pilsētas Austrumu izpilddirekcija*).

Financial Activity F1.1 ‘Allocation of municipal budget resources for neighbourhood development’

[Responsible institution - Financial Department of Riga City Council]

There exist several financial mechanisms of Riga municipality: Municipal infrastructure fund, Municipal investment programme, which can be used for financing neighbourhood development activities. A target-oriented coordination of the municipal budget of Riga City is necessary. The coordinating role should be appointed to the municipal unit responsible for integrated development of a particular neighbourhood in accordance with the Organizational Activity O1.1. (This financial activity is in accordance with the recommendation R1.3 ‘Part of income from City infrastructure development fund should be redirected on development projects in neighbourhoods’).

Financial Activity F1.2 ‘Establishment of Municipal fund for neighbourhood development’

[Responsible institution - Riga City Council]

A suitable solution for financing integrated urban development activities would be establishment of a municipal fund for neighbourhood development; the financial resources for the fund could come from municipality, private companies and individuals. Primary goal of the fund could be financing development activities carried out by neighbourhood inhabitants and non-governmental organizations. (This financial activity is in accordance with the recommendation R1.8 ‘A ‘Neighbourhood initiative fund’ should be created in order to facilitate inhabitant involvement in local development processes’).

2. Multi-apartment buildings (financing and organization)

To facilitate realization of the activities A2.1 to A2.6 described in this document, chapter “Multi-apartment buildings (development actions”, organizational and financial solutions were analyzed and the most efficient ones were found.

Organizational Activity O2.1 ‘Establishment of a Municipal Energy service company (a specialized Municipal building renovation company)’

[Activity is included in the “Riga sustainable energy action plan 2010-2020” approved by Riga City Council on July, 2010.]

[Responsible institution - Riga City Council]

This organizational activity contributes in implementation of the development activity A2.1 ‘Renovation of multi-apartment buildings in Jugla’ and especially helps solving the problems P2.4, P2.5 (P2.5a, P2.5b, P2.5c) and P2.7 (P2.7a, P2.7b, P2.7c). It is in accordance with the recommendation R2.3 ‘The multi-apartment building renovation should be organized by the Municipality’.

Establishment of a Municipal Energy Service Company would be the most appropriate solution to start a large-scale building renovation not only in Jugla but also in other neighbourhoods of Riga. A possible cooperation scheme between this company and the existing municipal building management company can be seen in Pic.28. [2]

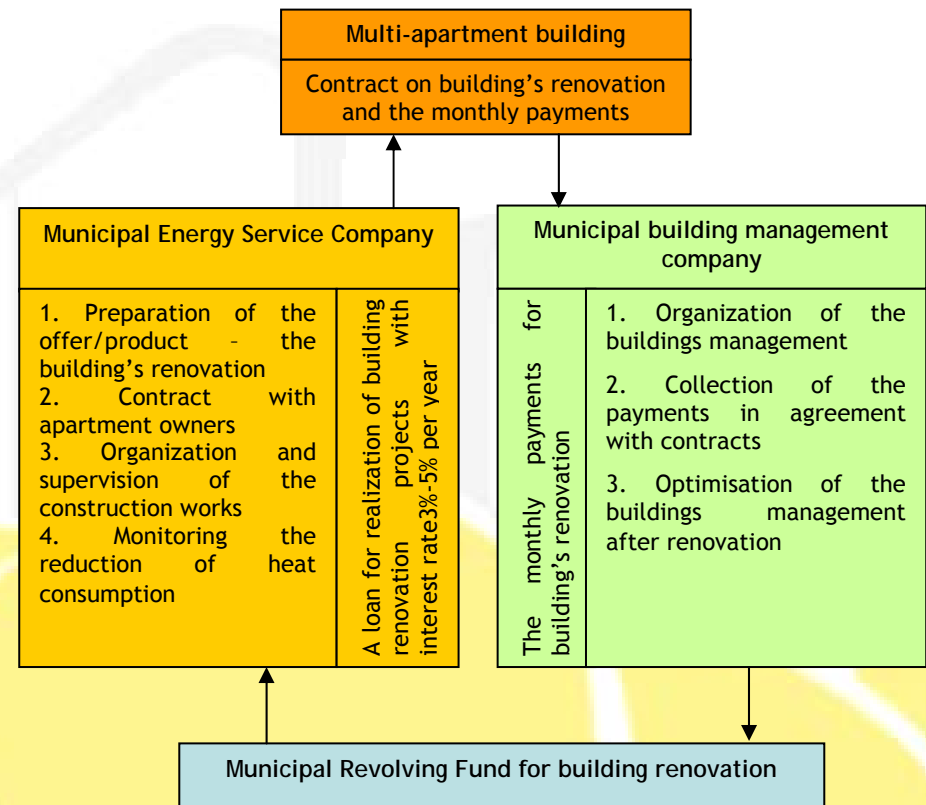

Pic.28, Functional scheme of cooperation between Municipal Energy service company and Building management companies: Municipal Energy Service Company takes loan from the Revolving Found (or other source) and provides building renovation service to apartment owners of multi-apartment buildings; apartment owners repay the renovation costs in a form of monthly payments to building's manager, the building's manager then returns money to the Revolving Fund. [2]

Financial Activity F2.1 'Development of a revolving fund for financing of multi apartment building renovation'

[Activity is included in the "Riga sustainable energy action plan 2010-2020" approved by Riga City Council on July, 2010.]

[Responsible institution - Riga City Council]

In the frame of *Urb.Energy* project the financial instruments and schemes supporting multi-apartment building renovation and available on municipal, state and EU level were analyzed [4] and establishment of the Revolving Fund was found as the most appropriate solution for Riga. This financial activity would contribute in implementation of the development activity A2.1 'Renovation of multi-apartment buildings in Jugla' and especially would help solving the problems P2.7 (P2.7a, P2.7b). Activity is in accordance with the recommendation R2.2 "To finance large-scale multi-apartment building renovation in Riga a financial instrument - Revolving Fund - should be established". Operational scheme of the Revolving Fund can be seen in Pic.29.

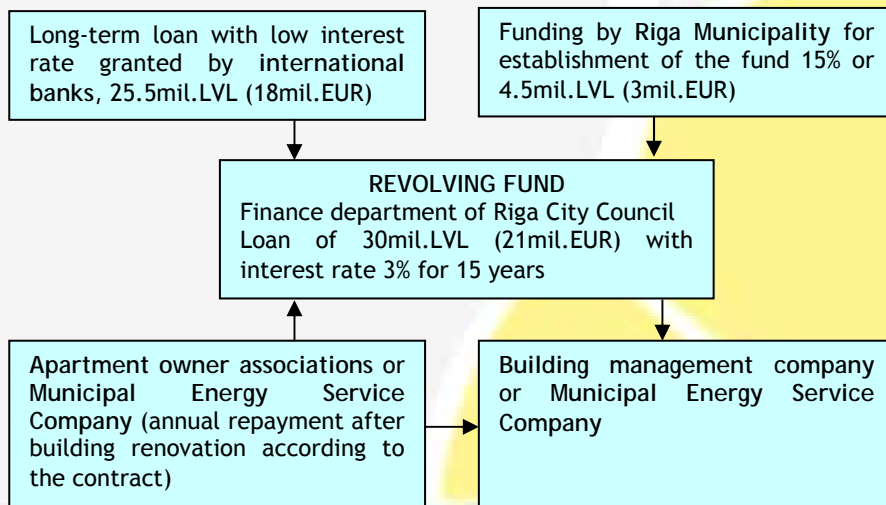

Pic.29, Operational scheme of a Revolving Fund for multi-apartment building renovation (Riga sustainable energy action plan 2010-2020)

Financial Activity F2.2 'Provision of co financing also for those renovation measures that do not improve building's energy efficiency'

[Responsible institution - State government, Riga City Council]

A financial support mechanism (additional one or as a part of the existing support programs) should be developed for co financing those measures that do not improve building energy efficiency but are urgently needed, such as renovation of building's electricity supply system, cold water supply system and sewerage system. This activity would solve problem P2.6a and would help improving quality of building renovation (P2.6).

The estimated renovation costs and annual savings of all not renovated multi apartment buildings in Jugla [2]

1.program (minimal):

Average renovation costs - 65 LVL/m². (93 EUR/m²).
 Total costs in Jugla - 36,8 mil.LVL (52.6 mil.EUR).
 Reduction of heat consumption - 50% or 41 GWh (1,8 mil.LVL 2.6 mil.EUR).

2.program (medium):

Average renovation costs - 94 LVL/m² (134 EUR/m²).
 Total costs in Jugla - 53,6 mil.LVL (76.6 mil.EUR).
 The possible reduction of heat consumption - 58 GWh (2,5 mil.LVL 3.6mil.EUR).

3.program (maximal):

Average renovation costs - 132 LVL/m² (189 EUR/m²).
 Total costs in Jugla 75,4 mil.LVL (107.7 mil.EUR).
 Reduction of heat consumption - 85% or 70 GWh (3,1 mil.LVL 4.4mil.EUR).

To estimate the renovation costs a very detailed analyses in a form of energy audit was carried out for six multi-apartment buildings belonging to three the most typical series in Jugla (No.464, No.316 and 12-storey buildings) The buildings with the lowest and the highest heat energy consumption were analysed for these series. The energy audit reports are available as parts of document [2].

A heat price 44 LVL/MWh (31 EUR/MWh) (June, 2010) was used in calculations.

For description of the programs, please, see chapter „Development actions, Multi-apartment buildings“ and document [2].

3. Energy supply *(financing and organization)*

Financial Activity F3.1 'Use of the existing EU financial mechanisms for rise of energy production efficiency'

[Responsible institution - small and medium sized industrial enterprises]

For implementation of activity A3.3 small and medium sized industrial enterprises should use the available finances of EU support programs (administered by Ministry of Economics) to implement technologies for utilization of the heat energy unused in manufacturing processes to additionally produce heat and electric energy without fuel incineration.

Financial Activity F3.2 'Establishment of financial mechanisms to support projects for promotion of biogas use'

[Responsible institution - Ministry of Economics]

For implementation of activity A3.4 a financial mechanism should be created to support production of appropriately qualitative biogas that would be suitable for feeding in the existing natural gas distribution network and storage facility after liberalization of gas market. It is desirable to establish a financial support mechanism for construction of biogas production facilities and their integration in the existing natural gas distribution network.

Financial Activity F3.3 'Continuation of financial support mechanisms to increase the share of renewable energy sources in energy production'

[Responsible institution - Ministry of Economics, Ministry of environmental protection and regional development, Riga City Council]

In short term the financial support mechanisms to increase the share of renewable energy sources in energy production are necessary. In middle term because of the rising fossil fuel prices, necessity for such a support will decrease.

Summary

1. Urban areas (summary)

Analysis of urban areas of Jugla (the current condition and the possible future improvements) in total found 7 problems (with 19 sub problems), 14 development activities, which should be carried out by implementing 2 organizational and 2 financial activities, and 9 recommendations for the development activities were given.

The activities listed below contribute in reaching the following aims of the “Riga long-term development strategy till the year 2025”:

- Priority Aim PA4 ‘Life in a city with qualitative neighborhoods’;
- Strategical Aim SA10 ‘Green city with good environmental quality’.

Problems
P1.1 ‘Quality of the public outdoor space is low’
P1.1a ‘Quality of the inner yards of the multi-apartment buildings is low’
P1.1b ‘Greenery, waterfronts and woods are underdeveloped’
P1.1c ‘The car parking places do not cover the demand’
P1.1d ‘Public outdoor space in Jugla is not adjusted for hadicaped people’
P1.1f ‘Visual quality of buildings is low’
P1.2 ‘Several territories available for development of Jugla have difficult usage conditions’
P1.2a ‘Several territories have high groundwater’
P1.2b ‘The territories of Jugla around the lakes have a relatively high flood risk’
P1.2c ‘Several territories of Jugla are degraded’
P1.3 ‘Spatial structure of Jugla is very complex’
P1.3a ‘Territory located above Riga-Vidzeme railway is not unified with the rest of Jugla’
P1.3b ‘Jugla has not a strong local centre’
P1.4 ‘Social infrastructure of Jugla is not fully suffiecient’
P1.4a ‘The existing kindergartens in Jugla do not cover all the demand’
P1.4b ‘Existing recreational possibilities do not cover all the demand’
P1.5 ‘Several parts of Jugla are not accessible for some types of vehicles’
P1.5a ‘Public transport network does not cover Fishermens village in Jugla’
P1.5b ‘Jugla is not covered by bicycle path network and lacks bicycle parking places’
P1.6 ‘Activity of residents of Jugla is low’

P1.6a 'Jugla has not a distinguished identity in perception of its residents'
P1.6b 'Residents of Jugla show no initiative to improve their neighbourhood'
P1.7 'Economic activity is low in Jugla'
P1.7a 'Number of work places is too small in Jugla'
P1.7b 'Residents of Jugla have a low paying capacity'
P1.7c 'Visitors and service users are not attracted to Jugla'

Development activities	Problems	Recommendations	Responsible institutions
A1.1 'Provision of overnight parking places for multi-apartment building inhabitants'	P1.1a, P1.1c	R1.1, R1.2	District administration of Riga City Council; Municipal company "Rīgas satiksme (Riga traffic)"; Traffic Department of Riga City Council
A1.2 'Reconstruction of the existing greenery and creation of additional greeneries'	P1.1b, P1.4b, P1.7c	R1.3	Municipal agency "Rīgas dārzi un parki (Gardens and parks of Riga)"
A1.3 'Improvement of inner yards of multi-apartment buildings'	P1.1a, P1.1b	R1.4	Housing and Environment Department of Riga City Council; Municipal agency "Rīgas dārzi un parki (Gardens and parks of Riga)"; Municipal agency "Rīgas gaisma (Lights of Riga)"
A1.4 'Adaptation of street infrastructure for handicapped people'	P1.1d	R1.5	Traffic Department of Riga City Council
A1.5 'Revitalization of former industrial zones and brown field sites'	P1.2a, P1.2c, P1.7	R1.3, R1.6, R1.7	City Development Department of Riga City Council
A1.6 'Improvement of Jugla Lake waterfront'	P1.2b, P1.4 b, P1.7c	R1.2, R1.3	District administration of Riga City Council; Housing and Environment Department of Riga City Council
A1.7 'Construction of additional kindergartens'	P1.4a		Education, Youth and Sports Department of Riga City Council; Property Department of Riga City Council
A1.8 'Development of recreation possibilities in woods'	P1.1b, P1.4b, P1.7c	R1.3	Municipal company "Rīgas meži (Riga woods)" of Riga City Council
A1.9 'Construction of additional pedestrian crossings'	P1.1	R1.3	Traffic Department of Riga City Council
A1.10 'Improvement of sidewalks and bicycle paths'	P1.1, P1.3a, P1.5b	R1.3	Traffic Department of Riga City Council
A1.11 'Provision of bicycle parking facilities'	P1.5b	R1.3	Traffic Department of Riga City Council
A1.12 'Construction of additional railway crossing for pedestrians'	P1.3a, P1.5a	R1.3	Traffic Department of Riga City Council
A1.13 'Organization of inhabitant involvement in neighbourhood development processes'	P1.6b	R1.2	District administration of Riga City Council
A1.14 'Promotion of Jugla visual identity'	P1.6a	R1.2	District administration of Riga City Council

Recommendations	Development activities
R1.1 As a part of Riga neighbourhood spatial planning development of strong neighbourhood centres should be considered (also in Jugla)	A1.1-A1.14
R1.2 To elaborate a neighbourhood transport and parking concept to ensure sustainability of overnight parking for multi-apartment building inhabitants	A1.1
R1.3 The functions of District administration of Riga City Council should be extended to overtake the responsibility of issues related to city district development and realization of cross structural urban development projects	A1.1, A1.6, A1.13, A1.14
R1.4 Part of income from City infrastructure development fund should be redirected on development projects in neighbourhoods	A1.2, A1.5, A1.6, A1.8-A1.12
R1.5 Improvements of inner yards of multi-apartment buildings should be carried out according to the elaborated visual identity of Jugla	A1.3
R1.6 Adoption of infrastructure for blind people should be done in cooperation with Latvian Blind People Society	A1.4
R1.7 To elaborate a programme of terms and conditions for investment attraction to ensure high quality revitalization of brown fields for future neighbourhood development, public infrastructure for these sites should be provided by Municipality	A1.5
R1.8 Municipality should provide support to local companies for start-up, possibly by transforming tasks and objectives of the existing grant program "Atspēriens (Take-off)"	A1.5
R1.9 A 'Neighbourhood initiative fund' should be created in order to facilitate inhabitant involvement in local development processes	A1.13

Financing and organization activities	Development activities	Responsible institution
O1.1 'Inclusion of integrated urban development approach in planning of Riga neighbourhoods'	A1.1-A1.14	City Development Department of Riga City Council
O1.2 'Establishment of a structural unit responsible for integrated development of neighbourhoods'	A1.1-A1.14	Riga City Council
F1.1 'Allocation of municipal budget resources for neighbourhood development'	A1.1-A1.14	Financial Department of Riga City Council
F1.2 'Establishment of Municipal fund for neighbourhood development'	A1.1-A1.14	Riga City Council

2. Multi-apartment buildings (summary)

Analysis of multi-apartment buildings of Jugla (the current condition and the possible future improvements) in total found 7 problems (with 12 sub problems), 6 development activities, which should be carried out by first implementing 1 organizational and 2 financial activities, and 19 recommendations for the development activities were given.

The activities listed below contribute in reaching the following aims of the "Riga long-term development strategy till the year 2025":

- Priority Aim PA4 'Life in a city with qualitative neighborhoods' (Task T4.5 'Improvement of the visual and aesthetic quality of the neighborhoods of the city');
- Strategical Aim SA12 'A city with qualitative dwellings' (Task T12.3 'Promotion of renovation and facilitation of privately owned buildings', Task T12.7 'Promotion of rational use of heat and electricity in dwellings').

Problems
P2.1 'Technical quality of multi-apartment buildings is low'
P2.2 'Quality of indoor climate in apartments is very low'
P2.2.a 'Air humidity in apartments is often too low or too high'
P2.2.b 'CO2 concentration in apartments is often extremely high'
P2.2.c 'Inside air temperature in apartments often is too low or too high'
P2.3 'Heat energy consumption of multi-apartment buildings is very high'
P2.4 'Apartment owners do not realize the necessity of renovation, do not believe that quality can be ensured and do not trust private building managers'
P2.5 Apartment owners are not able to renovate their buildings and ensure quality of renovation
P2.5.a Apartment owners lack experience and knowledge on decision-making
P2.5.b Apartment owners lack experience and knowledge on management of their buildings
P2.5.c Apartment owners lack experience and knowledge on organization of building renovation
P2.6 'The current approach to building renovation does not ensure high quality of renovation'
P2.6a 'Measures, that do not improve building energy efficiency but are urgently needed, are not included in renovation'
P2.6.b 'The normative acts do not state that renovation of ventilation system is a mandatory part of building renovation'
P2.6.c 'Energy efficient building renovation solutions are not in accordance with the current fire-prevention standards'
P2.7 'The current financial schemes for building renovation do not promote renovation'
P2.7.a Apartment owners cannot cover renovation expenses from their savings
P2.7.b Apartment owners are not willing to take bank loans
P2.7.c Significant part of apartment owners has a very low paying capacity

Development activities	Problems	Recommendations	Responsible institution
A2.1 'Renovation of multi-apartment buildings in Jugla'	P1.1f, P2.1, P2.2, (P2.2a, P2.2b, P2.2c), P2.3,	R2.1-R2.19, R2.11-R2.15, R2.16-R2.19	Riga City Council
A2.2 'Preparation of a one, unified product <i>building's renovation</i> that can be easily understood by the apartment owners'	P2.4, P2.5	R2.6 -R2.8, R2.16-R2.19	Riga City Council
A2.3 'Supplementation of the normative acts with a statement that renovation of ventilation system is a mandatory part of building renovation'	P2.6b		State government
A2.4 'Integration of fire-prevention standards and energy efficient building renovation solutions'	P2.6c		State government
A2.5 'Organization of training courses for construction work supervisors and construction workers about the building renovation technologies and organizational issues'	P2.6		Riga City Council
A2.6 'Development of a common visual image (visual identity) for the blocks or groups of multi-apartment buildings after renovation in Jugla'	P2.4, P2.6		Riga City Council

Recommendations	Development activities
R2.1 To renovate buildings according to the 3.program to reach the maximum heat energy savings, thus helping to achieve the requirements of EC directive on energy performance of buildings and reducing renovation costs later.	A2.1
R2.2 To finance large-scale multi-apartment building renovation in Riga a financial instrument - Revolving Fund - should be established.	A2.1
R2.3 The multi-apartment building renovation should be organized by the Municipality	A2.1
R2.4 Renovation costs should be reduced by carrying out the renovation for groups of buildings.	A2.1
R2.5 Only companies with established company's quality management system should be chosen for management of renovation and realization of the construction works.	A2.1
R2.6 In the contract between apartment owners and the company that realizes the renovation, a point should be included that the energy savings stated in energy audit must be reached in the result of renovation.	A2.1, A2.2
R2.7 When the decision to carry out renovation is made the apartment owners should make a mutual contract about the usage of the common property and register that in the Land book stating the monthly payments as an obligation.	A2.1, A2.2
R2.8 To avoid any additional construction works and additional costs the technical design must be developed very detailed.	A2.1, A2.2
R2.9 During realization designer and field supervision should be ensured.	A2.1
R2.10 To prepare a standardized renovation technical design for all series of buildings where glazing of all loggias is included.	A2.1
R2.11 Instead of insulation of cellar ceiling the cellar floor should be insulated.	A2.1
R2.12 Instead of insulation of attic floor the roof of the building should be insulated.	A2.1
R2.13 Installation of new windows should be done in the wall insulation area.	A2.1
R2.14 To prepare a detailed technical design of the ventilation system with heat recovery and realize it.	A2.1
R2.15 Balconies of the 5-storey multi apartment buildings should be dismantled.	A2.1
R2.16 In the order of the renovation's technical design the conclusions of the energy audit and the technical inspection should be included as binding	A2.6, A2.2
R2.17 It should be emphasized that after renovation the visual quality of the building and facilitation of the area will be significantly higher	A2.7, A2.2
R2.18 The construction works should be realized in such a way that monthly payment for the renovation would be less or equal with the monthly payment for the saved heating energy.	A2.1, A2.2
R2.19 The monthly payments should be set the same each month over a period of one year and at the end of each heating season a recalculation of the new monthly payment should be done (to significantly save administration costs)	A2.1, A2.2

Financing and organization activities	Development activities	Responsible institution
O2.1 'Establishment of a Municipal Energy Service Company (a specialized Municipal building renovation company)'	A2.1	Riga City Council
F2.1 'Development of a revolving fund for financing of multi apartment building renovation'	A2.1	Riga City Council
F2.2 'Provision of co financing also for those renovation measures that do not improve building's energy efficiency'	A2.1	State government, Riga City Council

3. Energy supply (summary)

Analysis of energy supply system of Jugla and Riga (the current condition and the possible future improvements) in total found 3 problems (with 8 sub problems), 5 development activities, which should be carried out by implementing 3 financial activities, and 5 recommendations for the development activities were given.

The activities listed below contribute in reaching the following aims of the “Riga long-term development strategy till the year 2025”:

- Strategical aim SA10 ‘Green city with good environmental quality’ (Task T10.5 ‘Improvement of air quality’);
- Strategical aim SA12 ‘A city with qualitative dwellings’ (Task T12.7 ‘Promotion of rational use of heat and electricity in dwellings’).

Problems
P3.1 ‘The share of renewable energy sources in energy production of Riga is low’
P3.1a ‘Biogas currently is used only locally’
P3.1b ‘Integration of biogas and natural gas distribution networks is not possible currently’
P3.1c ‘Use of fossil fuel creates CO ₂ emissions’
P3.2 ‘Use of fuel for energy production in local heat sources creates air pollution’
P3.2a ‘Use of fuel for energy production in local heat sources creates NO _x pollution in air’
P3.2b ‘Use of fuel for energy production in local heat sources creates mechanical particle pollution in air’
P3.2c ‘Technology for cleaning of flue gases and NO _x reduction are not commonly used for small scale local burners, boilers and ovens’
P3.3 ‘Reduced heat demand due to buildings renovation can affect efficiency of the city energy supply’
P3.3a ‘Reduced heat load reduces the efficiency of cogeneration’
P3.3b ‘Reduced heat loads may reduce efficiency of district heating networks’

Development activities	Problems	Recommendations	Responsible institution
A3.1 ‘Restriction of construction of local heat sources in city areas where NO _x and mechanical particle concentration in air is high’	P3.2		Riga City Council, Ministry of environmental protection and regional development
A3.2 ‘Connection of local heat source consumers to the district heating system’	P3.2, P3.3		Riga City Council, Ministry of environmental protection and regional development
A3.3 ‘Raise of energy production efficiency’	P3.3	R3.1, R3.2, R3.3	Riga City Council, Ministry of environmental protection and regional development
A3.4 ‘Increase of biogas production and use after the gas supply market liberalization’	P3.1		Riga City Council, Ministry of environmental protection and regional development
A3.5 ‘Increase range of available renewable energy sources for heat and electric energy production’	P3.1	R3.4, R3.5	Ministry of Economics, Ministry of environmental protection and regional development, Riga City Council

Recommendations	Development activities
R3.1 Implementation of technologies for utilization of low potential heat of flue gases should be promoted for the centralized heat sources where only heat is produced.	A3.3
R3.2 In the thermal power stations absorption heat pumps should be used to utilize the thermal energy unused in cogeneration process.	A3.3
R3.3 In the existing industry and electricity production facilities, heat energy of low potential heat carrier (85°C-130°C) should be utilized for electric energy production by implementation of Organic Rankine Cycle technology.	A3.3
R3.4 The geothermal energy can potentially be used in Riga, a survey project should be carried out.	A3.5
R3.5 To increase the share of RES in the existing energy supply system that is currently based on the fossil fuel (thermal power stations, gas networks, storage facility) in Latvia and also in Riga synthetic gas could be used. Synthetic gas can be produced by utilisation of CO ₂ , water and wind and solar power used for extra electricity production. This would also allow to completely use wind and solar energy. After liberalization of gas supply market in Year 2014 in long term it is possible to produce and to integrate synthetic gas in the existing gas supply network and the underground storage facility similarly to the <i>solarfuel</i> pilot project in Germany.	A3.5

Financing and organization activities	Development activities	Responsible institution
F3.1 'Use of the existing EU financial mechanisms for rise of energy production efficiency'	A3.3	Small and medium sized industrial enterprises
F3.2 'Establishment of financial mechanisms to support projects for promotion of biogas use'	A3.4	Ministry of Economics
F3.3 'Continuation of financial support mechanisms to increase the share of renewable energy sources in energy production'	A3.4, A3.5	Ministry of Economics, Ministry of environmental protection and regional development, Riga City Council

Imprint

Riga City Council
Ratslaukums 1
Riga, LV-1539
Latvia

Phone +371-671-05122
Fax +371-671-05109

<http://www.riga.lv>
<http://www.urbenergy.eu>



Part-financed by the European Union (European Regional Development Fund and European Neighbourhood and Partnership Instrument).

